

RAY ELECTRIC OUTBOARDS, INC. INSTALLATION INSTRUCTIONS

Applicable to Motors Serial No. 400 and Greater

READ THESE INSTRUCTIONS THOROUGHLY BEFORE BEGINNING INSTALLATION

Be sure your boat can safely carry your Ray system with batteries plus other loads (people, gear, etc.).

SAFE BOAT LOADING AND OPERATION ARE THE OWNER'S RESPONSIBILITIES!

WARNING: TO AVOID INJURY OBSERVE SAFETY PRECAUTIONS. In particular:

1. **WHEN CONNECTING BATTERIES, TAP WIRE MOMENTARILY ON TERMINAL BEFORE CONNECTING AS A FINAL CHECK AGAINST SHORTS. ABSENCE OF ARCS OR SPARKS INDICATES THE WIRE MAY BE CONNECTED.**
2. **BE CAREFUL NOT TO SHORT BATTERY TERMINALS WITH WRENCH WHILE MAKING CONNECTIONS. IT IS ADVISABLE TO REMOVE METALLIC RINGS, WATCHES, BRACELETS, ETC. WHEN CONNECTING OR DISCONNECTING BATTERIES.**
3. **IN THE FUTURE, ALWAYS DISCONNECT THE POWER PLUG AT THE MOTOR BEFORE MAKING ANY CONNECTIONS, DISCONNECTIONS, REPAIRS, ETC. INSIDE THE MOTOR HOUSING.**

WARNING - There is a danger that the Ray outboard may “twist itself off the transom” if not bolted to the transom through the holes in the lower end of each clamp (Step 2). Because of the large turning radius of the motor enough side thrust and leverage can develop to twist the clamps off the transom. Also rapid powerful reversing, necessary at times may put too much strain on the boat’s transom if the clamps are not bolted. Tiller models are particularly vulnerable to twisting off transom and present a real danger of being lost if operated in deep water without being bolted to the transom.

Tools Required: Screwdrivers, knife, wire cutters 9/16", 1/2" and 7/16" wrenches, and crimper for large wire terminals.

Locating and Storing Batteries

Batteries required: Six or eight 6V golf cart batteries depending on whether your motor is designed to operate on 36 or 48 volts.

Batteries are always connected electrically in series (+ to -) to produce 48 or 36 volts as illustrated in Figure 1. By varying the length of jumper wires and battery leads, batteries can be located anywhere on the boat and still be connected electrically as in Figure 1. Typical locations of batteries on boats are illustrated in Figures 2 through 5.

It is recommended that standard size plastic battery boxes (bottoms only) be used to protect the boat from acid spills. Batteries should be stored in seats or specially constructed boxes to protect them from weather.

Be sure ventilation is provided in sides of storage compartments to PREVENT ACCUMULATION OF HYDROGEN GAS AND POSSIBLE EXPLOSION. Batteries should be located to balance the boat, if the best performance is desired.

Step 1. Stow batteries and Connect Jumpers. Stow batteries in protective plastic boxes in the locations chosen. Connect batteries in the same compartment with the short jumper wires provided. Long jumpers must be made from the two long wires provided. Note that terminals are already installed on one end of these wires.

Excess wire cut from battery to motor leads also may be used -- see Step 2. To crimp on terminals, trim 1/2" of insulation from end of wire and crimp on terminal with an appropriate crimping tool. On pontoon boats route long jumpers between battery locations underneath deck, drilling holes in deck inside seats for passage of wire. Secure wire where necessary with staples or cable clamps (not furnished).

Step 2. Install the Outboard. Clamp the outboard in its running position on the transom and install the two 5/16 X 3" stainless steel bolts through transom and holes in lower end of clamps (See warning above.)

Step 3. Connect Battery Leads to Motor. Plug the battery plug into the plug at the front of the outboard. Route the white lead to +36, 48, or 60V the black lead to -36, 48, or 60V. See Figure 1. Leave some slack at the motor so there is no strain on the plug. On pontoon boats route wires underneath deck and support with staples or cable clamps, etc. Drill necessary holes through deck inside seats for passage of wires to batteries. After routing and securing these wires cut off excess at the battery end leaving adequate slack. Using crimp-on terminals, connect the white lead to the +48V battery terminal and the black lead to the -48V battery terminal.

Step 4. Install Control Console. Remote control motors only). Upon completion of Step 2, power will be connected to motor. REMOVE THIS POWER BY UNPLUGGING THE POWER PLUG AT MOTOR BEFORE PROCEEDING. Remove the base from the console by unscrewing the knob and the four screws in the ends of console. Leave the wires attached. Locate the position desired for the console and place the base at the center of this location with the rotary switch to the right. Fasten the base plate down with four #8 screws provided through the four holes at the corners of the base. Drill a 3/8" hole through the surface on which mounted through the 3/8" hole existing in the base. Carefully attach the control cable socket to the motor cable plug at the motor, turning the fastening ring clockwise until it stops. Now route the gray control cable to the console leaving some slack at the motor so there is no strain on the connector. Secure cable with staples or cable clamps at appropriate points. Run cable through the 3/8" hole in the console base. Pull slack up through hole and cut off excess cable about 6" above the console-mounting surface. With a knife cut about 3" of sheath from the cable, being careful not to cut individual wires or their insulation. Trim 3/16" of insulation from the end of each wire. Connect the wires to the terminal strip matching the color of wires on the other side of the terminal block. Push the wires into the holes in terminal block and tighten screws down on the wires with a small screwdriver. Now attach the nylon cable clamp about 1/2" from the end of the sheath to keep the cable from falling through the hole and relieve strain on the wires. Reattach the console cover to the base and replace knob on the lever.

Step 5. Operational Checks. BEWARE OF ROTATING PROPELLER. Reconnect power plug. Turn on key switch by turning key clockwise. Advance speed lever forward until propeller starts to turn. Run only at reduced speeds when out of water. Return speed lever to off, then pull back lever to reverse. Propeller should turn in reverse direction. If proper operation is not obtained, carefully check for proper connection of batteries and control wires according to these instructions.

Step 6. Connect Charger Leads to Batteries. The charger may be stored on or off boat. **DO NOT STORE CHARGER IN SAME COMPARTMENT WITH BATTERIES!** Charger must be adequately ventilated if stored in a seat. Seat should be open when charger is on. Failure to adequately ventilate charger voids warranty--see Limited One Year Warranty. The charger is connected to batteries by means of a gray power plug and a pair of #10 wire leads. The plug should be located in a position near the charger, or where the charger can be conveniently plugged in if charger is left off of boat. Route the red wire to +36, 48, or 60 volts and the black wire to -36, 48, or 60 volts as in Figure 1. Cut off excess wire leaving plenty of slack. Connect wires to battery terminals with the crimp on terminals provided. Turn on charger and check for operation indicated by current flow on the charger ammeter. **BE SURE KEY SWITCH IS OFF BEFORE CHARGING.**

Steering Connection

The outboard accepts conventional push-pull steering cable by means of the steering tube attached to the motor. The link arm is provided.

Accessory Connection

Running lights and low drain accessories such as small radios may be connected by "battery tapping" across any two adjacent batteries to obtain 12V. If more than one accessory, connect each to a different pair of batteries. Do not connect high, prolonged drain accessories such as trolling motors or radios. Provide separate batteries for these. Accessory operation should use a maximum of 20-ampere hours, such as 5 amps for four hours, 10 amps for two hours, etc.

CAUTION: To avoid electrolysis, it is important that no battery terminal in the system be connected to or grounded to metal boats such as pontoon boats. Grounding can occur through lights that use the base as one connection or through grounded radio chassis. For more details see Electrolysis in ELECTRICAL REPAIR MANUAL.

OPERATION AND MAINTENANCE INSTRUCTIONS contain additional information to help the customer get full satisfaction from the Ray Electric Outboard.

SYSTEM 500, 60 VOLTS

6-VOLT BATTERIES

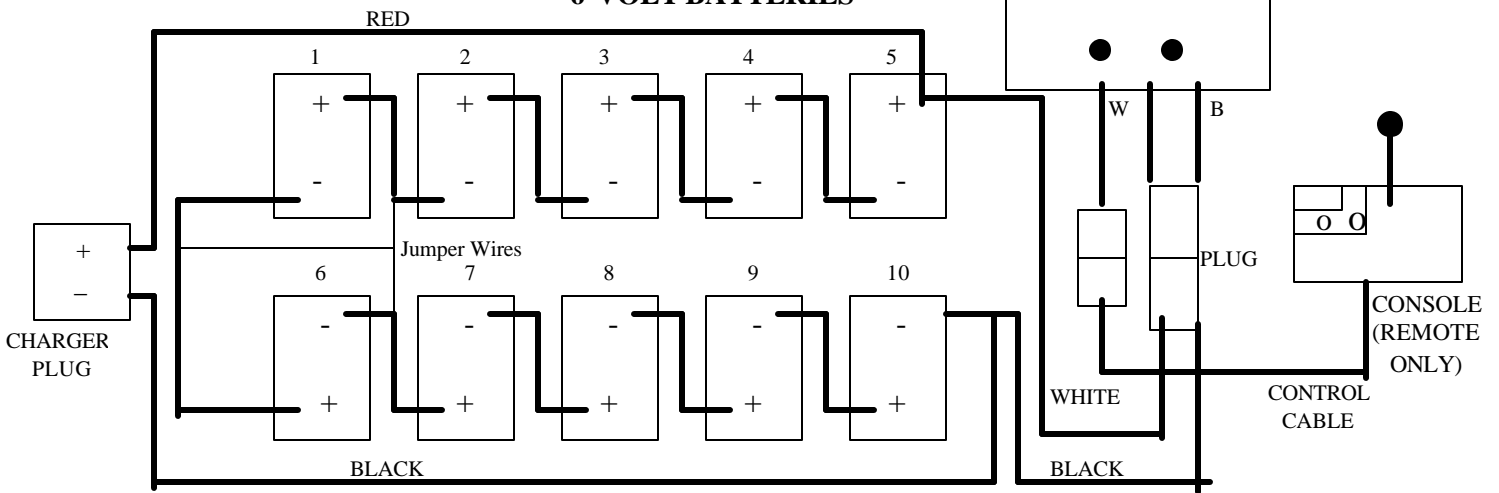

SYSTEM 400, 48 VOLTS

6-VOLT BATTERIES

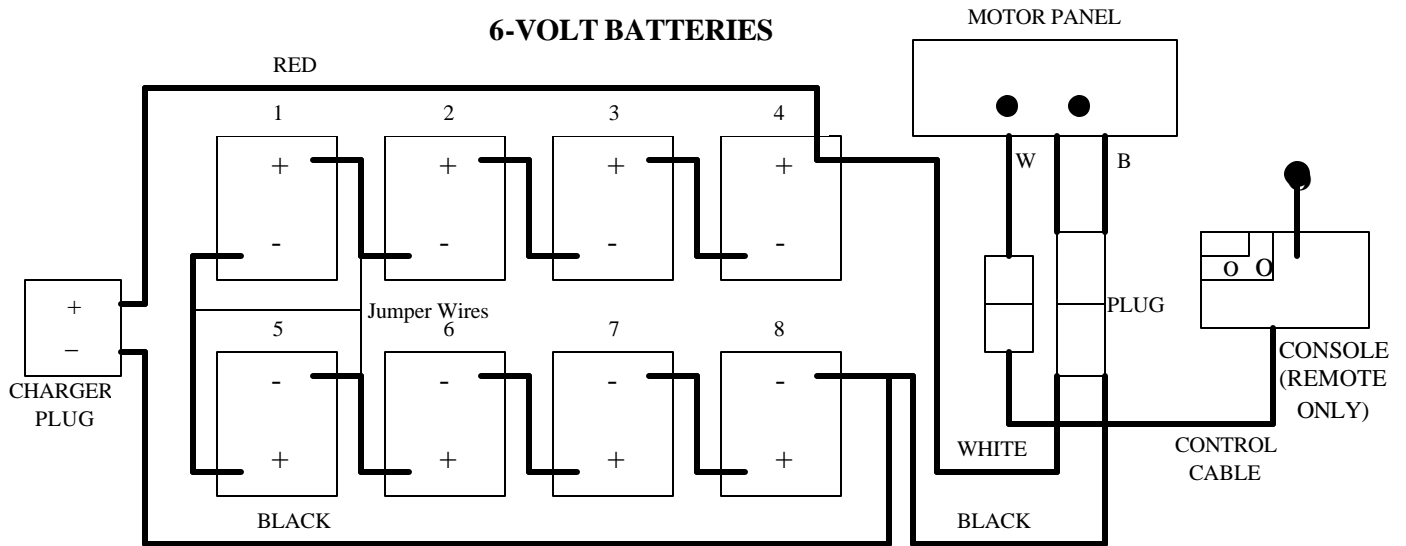

SYSTEM 300, 36 VOLTS

6-VOLT BATTERIES

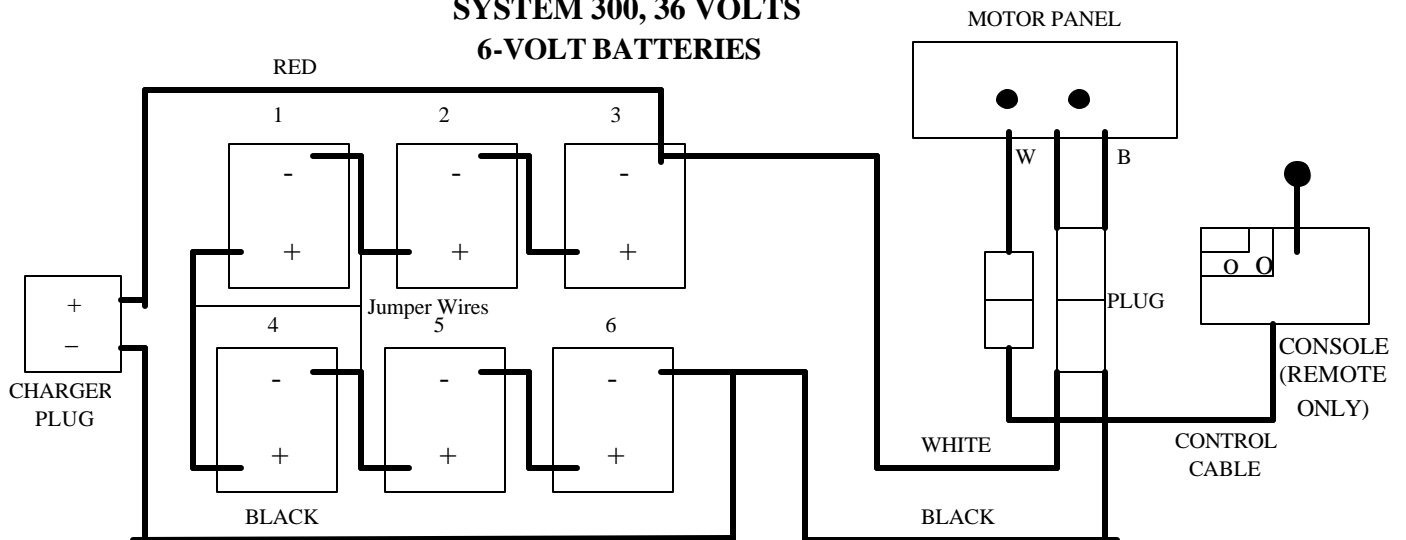

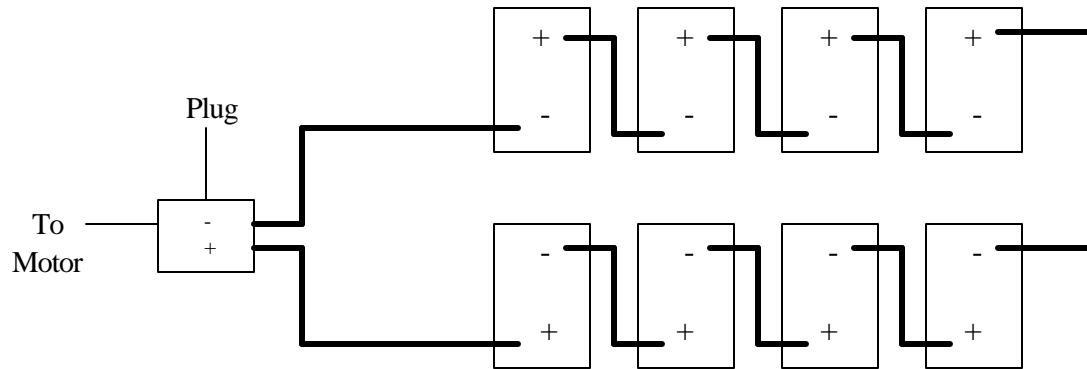

Installation with batteries in single location near center of boat

Figure 2

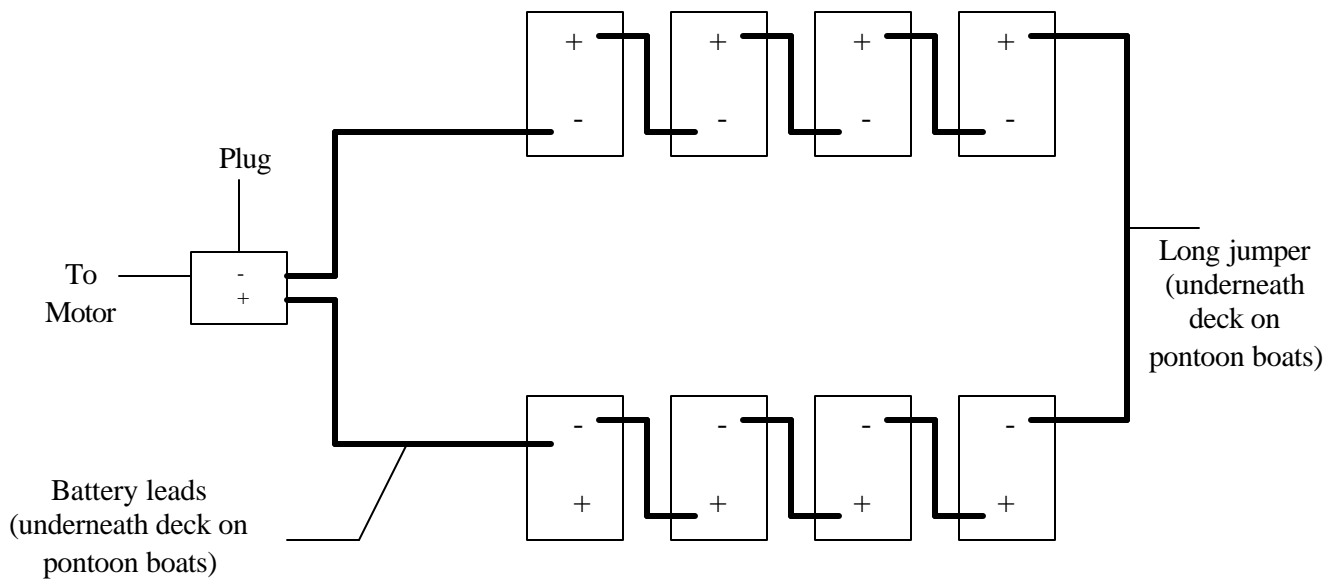

Installation in two locations on each side of boat

Figure 3

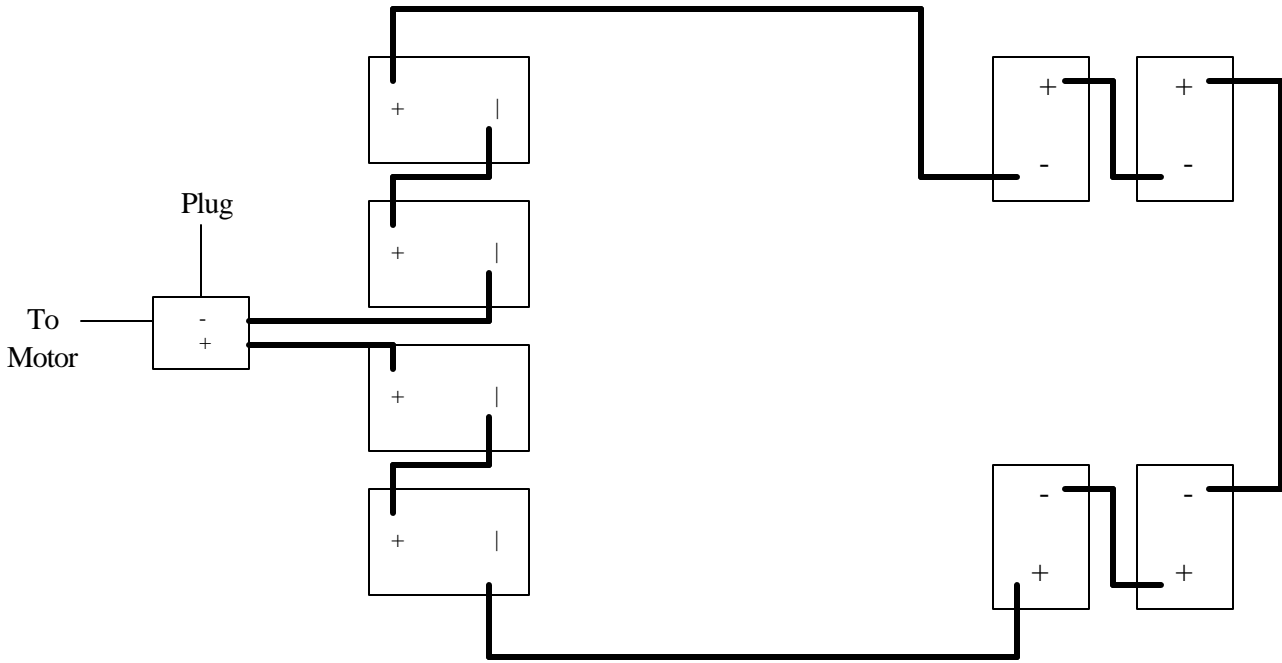

Installation in three locations such as front and rear seats of pontoon boat

Figure 4

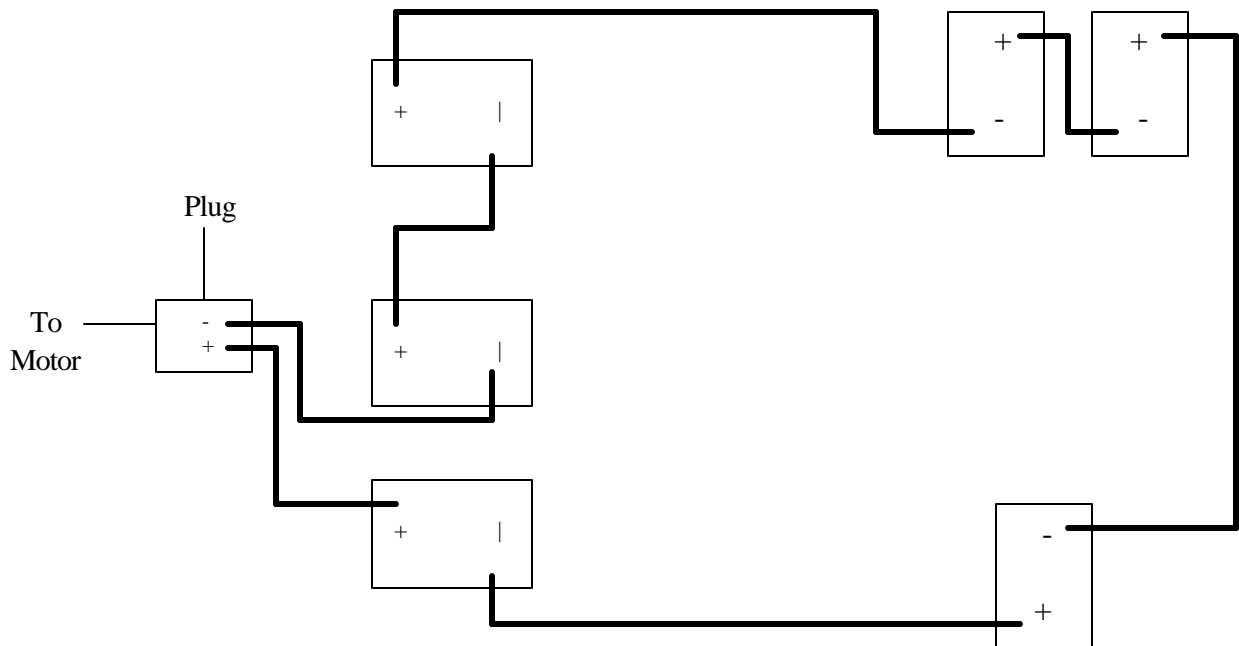

36V Installation in three locations to best balance a pontoon boat with front and rear seats

Figure 5